

# JET

**JSG-96**

**JSG-96.....708595M.....1~230V, 50Hz**

## **PARTS LIST**

**Walter Meier (TOOL) AG**  
Tämperlistrasse 5  
CH-8117 Fällanden  
Switzerland  
Phone +41 44 806 47 48  
Fax +41 44 806 47 58  
[jetinfo.eu@waltermeier.com](mailto:jetinfo.eu@waltermeier.com)  
[www.jettools.com](http://www.jettools.com)



P-708595M 2012-05

# JSG-96 Disc Sander Assembly

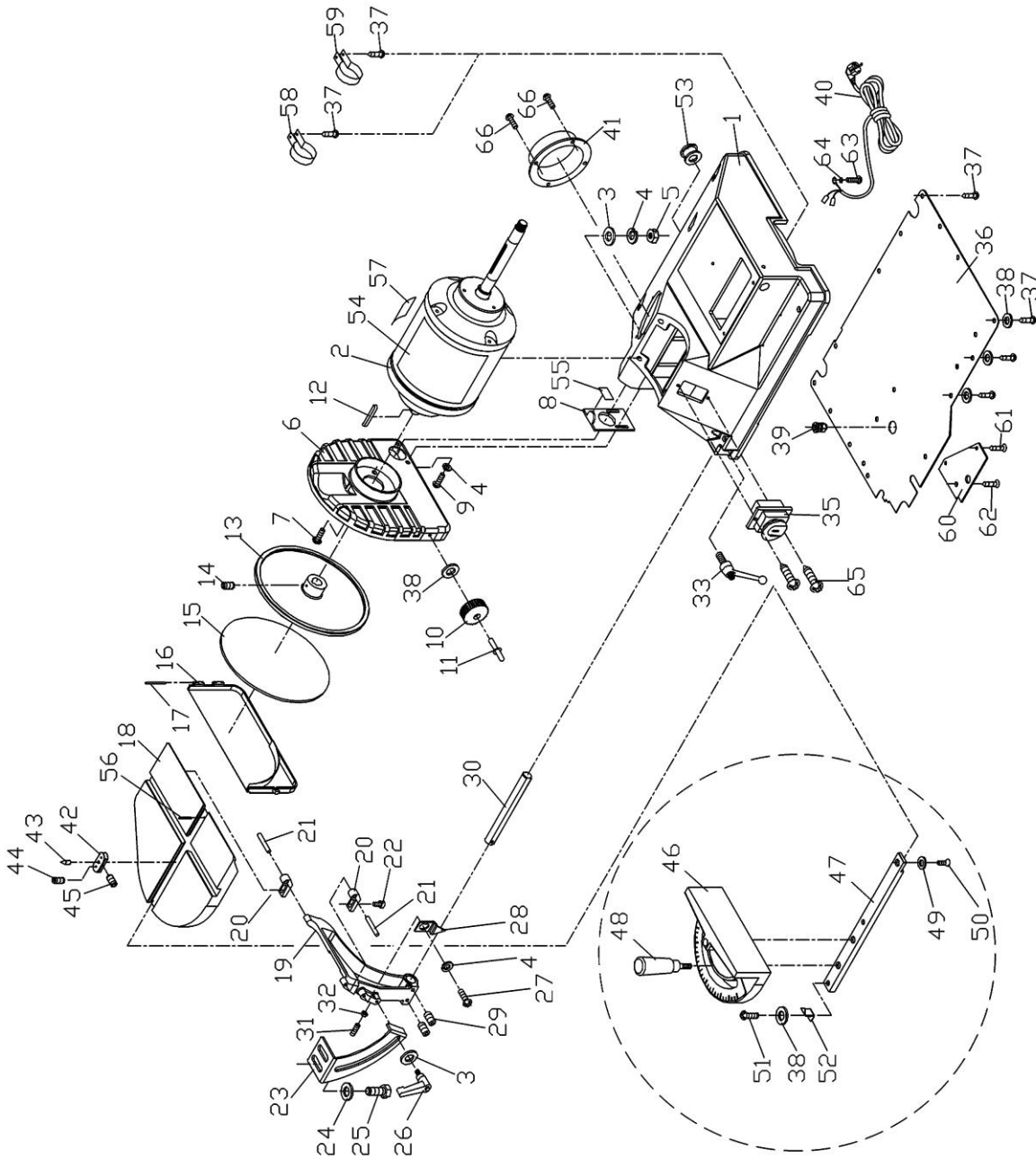

## JSG-96 Disc Sander Assembly

Index No.	Part No.	Description	Size	Qty.
1	JSG96-101A	Base		1
2	JSG96-102E	Motor		1
	JSG96-102AE	Starting Capacitor (not shown)		1
	JSG96-102BE	Running Capacitor (not shown)		1
3	TS-1550041	Flat Washer	M6	4
4	TS-1551041	Lock Washer	M6	7
5	TS-1540041	Hex Nut	M6	1
6	JSG96-106	Disc Cover		1
7	JSG96-107	Screw w/Washer	1/4x3/8	3
8	JSG96-108	Air Controller		1
9	JSG96-109	Tap Screw	1/4x1/2	2
10	JSG96-110	Lock Knob		1
11	JSG96-111	Rivet		1
12	JSG96-112	Key	5x5x25	1
13	JSG96-113	Disc		1
14	JSG96-114	Set Screw	#10x3/8	1
15	JSG96-115E	Sanding Disc		1
16	JSG96-116	End Cover		1
17	JSG96-117	Pin		1
18	JSG96-118	Compound Table		1
19	JSG96-119	Table Bracket		1
20	JSG96-120	Trunnion		2
21	JSG96-121	Pin		2
22	JSG96-122	Hex Socket Cap Screw	#10x5/8	2
23	JSG96-123	Table Support w/Scale		1
24	TS-0680031	Flat Washer	5/16	2
25	TS-0051021	Hex Head Screw	5/16x5/8	2
26	JSG96-126	Lock Handle		1
27	JSG96-127	Screw	1/4x3/8	1
28	JSG96-128	Pointer		1
29	TS-0270031	Set Screw	5/16x3/8	2
30	JSG96-130	Rod		1
31	JSG96-131	Set Screw	1/4x1	1
32	TS-0561011	Hex Nut	1/4	1
33	JSG96-133	Lock Handle	5/16x1	1
35	JSG96-135E	Switch		1
36	JSG96-136A	Plate		1
37	JSG96-137A	Tap Screw	3/16x3/8	19
38	TS-0680011	Flat Washer	3/16	5
39	JSG96-139E	Strain Relief		1
40	JSG96-140E	Power Cord		1
41	JSG96-141	Dust Chute		1
42	JSG96-142	Circle Gauge		1
43	JSG96-143	Tip		1
44	JSG96-144	Set Screw	1/4x1/4	2
45	JSG96-145	Set Screw	M4x6	1
46	JWBS18-403	Miter Gauge Body		1
47	JSG96-147	Guide Bar		1
48	JWBS18-401	Lock Handle		1
49	JWBS20-156	Guide Disc		1
50	JSG96-150	Pan Head Screw	1/4x5/16	1

## JSG-96 Disc Sander Assembly

Index No.	Part No.	Description	Size	Qty.
51	JSG96-151	Screw	#10x5/16	1
52	JWBS18-406	Pointer		1
53	JSG96-153	Cord Protector		1
54	JSG96-154E	I.D. Label		1
55	JSG96-155	Indication Label		1
56	JSG96-156	Roll Pin		1
57	JSG96-157E	Motor Label		1
58	JSG96-158	Holder-Small (Running Capacitor)		1
59	JSG96-159	Holder-Big (Starting Capacitor)		1
60	JSG96-160	Plate		1
61	JSG96-161	Tap Screw	3/16x5/8	2
62	JSG96-162	Screw	1/4-20x1/2	1
63	JSG96-163	Screw	#10-24x5/16	1
64	JSG96-164	Tooth Washer		1
65	JSG96-165	Tap Screw	M4X15	2
66	JSG96-166	Tap Screw	1/4"x3/8"	4
	JSG96-MGA	Miter Gauge Assembly (Items 38, 46 thru 52)		1
	JSG96-CGA	Circle Gauge Assembly (Items 42 thru 45)		1

# JSG-96 Belt Sander Assembly

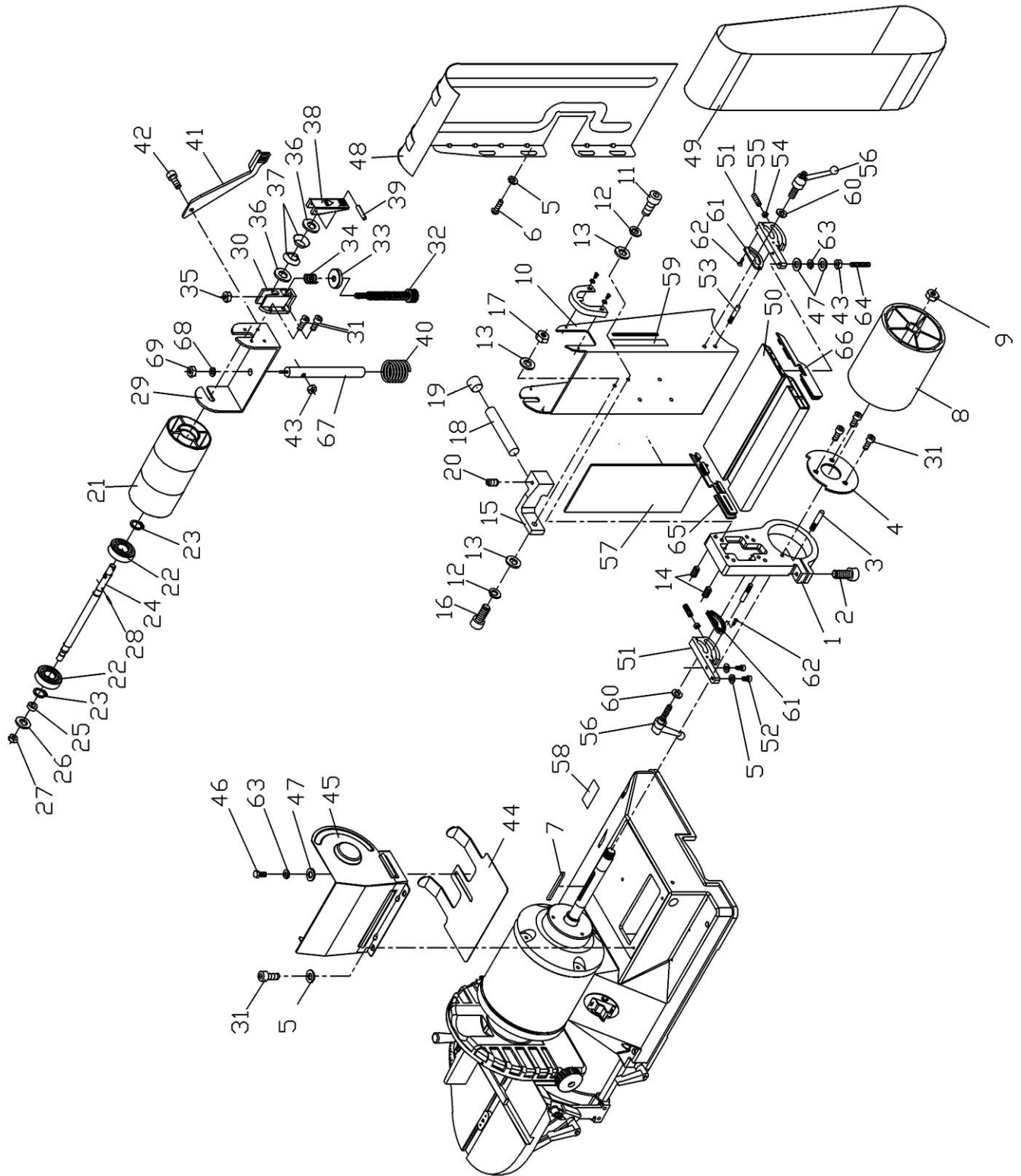

## JSG-96 Belt Sander Assembly

Index No.	Part No.	Description	Size	Qty.
1	JSG96-201	Bracket		1
2	TS-0208071	Hex Socket Cap Screw	5/16x1-1/4	1
3	JSG96-203	Pin		1
4	JSG96-204	Fixed Plate		1
5	TS-0680021	Flat Washer	1/4	8
6	JSG96-206	Screw	1/4x3/8	3
7	JSG96-207	Key	5x5x70	1
8	JSG96-208	Drive Drum		1
9	JSG96-209	Lock Nut	5/8-18UNF	1
10	JSG96-210	Belt Support		1
11	JSG96-211	Hex Socket Cap Screw	5/16x5/8	4
12	TS-0720081	Lock Washer	5/16	5
13	TS-0680031	Flat Washer	5/16	6
14	TS-0270031	Set Screw	5/16x3/8	4
15	JSG96-215	Bracket		1
16	TS-0208061	Hex Socket Cap Screw	5/16x1	1
17	TS-0561021	Hex Nut	5/16	1
18	JSG96-218	Rod		1
19	JSG96-219	Pad		1
20	JSG96-220	Set Screw	1/4x3/8	1
21	JSG96-221	Follow Roller		1
22	BB-6201ZZ	Ball Bearing		2
23	JSG96-223	C-Ring	STW-11	2
24	JSG96-224	Shaft		1
25	JSG96-225	Bushing		1
26	TS-0680041	Flat Washer	3/8	1
27	JSG96-227	Lock Nut	3/8	1
28	JSG96-228	Roll Pin	4x20	1
29	JSG96-229	Support Bracket		1
30	JSG96-230	Micro-Adjusting Seat		1
31	TS-0207021	Hex Socket Cap Screw	1/4x1/2	6
32	JSG96-232	Screw		1
33	JSG96-233	Adjusting Knob		1
34	JSG96-234	Spring		1
35	JSG96-235	Lock Nut	M6	1
36	JSG96-236	Washer		2
37	JSG96-237	Disc Spring		2
38	JSG96-238	Lock Handle		1
39	JSG96-239	Roll Pin	3x20	1
40	JSG96-240	Spring		1
41	JSG96-241	Eccentric Handle		1
42	JSG96-242	Hex Socket Cap Screw	1/4x1-1/4	1
43	JSG96-243	Lock Nut	1/4	2
44	JSG96-244	Air Controller (Belt)		1
45	JSG96-245	Dust Chute		1
46	JSG96-246E	Hex Head Bolt	1/4x1/2	1
47	JSG96-247	Flat Washer	1/4x3/4	3
48	JSG96-248	Back Cover		1
49	JSG96-249	Sanding Belt		1
50	JSG96-250	Belt Table		1
51	JSG96-251	Trunnion		2
52	TS-0050021	Hex Socket Cap Screw	1/4x5/8	2
53	JSG96-253	Guide Pin		2

## JSG-96 Belt Sander Assembly

Index No.	Part No.	Description	Size	Qty.
54	TS-0561011	Hex Nut	1/4	2
55	JSG96-255	Set Screw	1/4x3/4	2
56	JSG96-256	Lock Handle	5/16x1-1/4	2
57	JSG96-257	Graphite Pad		1
58	JSG96-155	Indication Label		1
59	JSG96-259E	Loosen/Tighten Label		1
60	JSG96-260	Flat Washer	1/4x9/16x1/8	2
61	JSG96-261	Serrated Plate		2
62	JSG96-262	Phillips Tap Screw	M3x10	4
63	JSG96-263	Lock Washer	1/4	1
64	JSG96-264	Set Screw	1/4x1-1/2	1
65	JSG96-265	Left Cover		1
66	JSG96-266	Right Cover		1
67	JSG96-267	Rod		1
68	JSG96-268	Flat Washer	3/8	1
69	JSG96-269	Lock Nut	3/8	1

JSG-96 Closed Stand Assembly

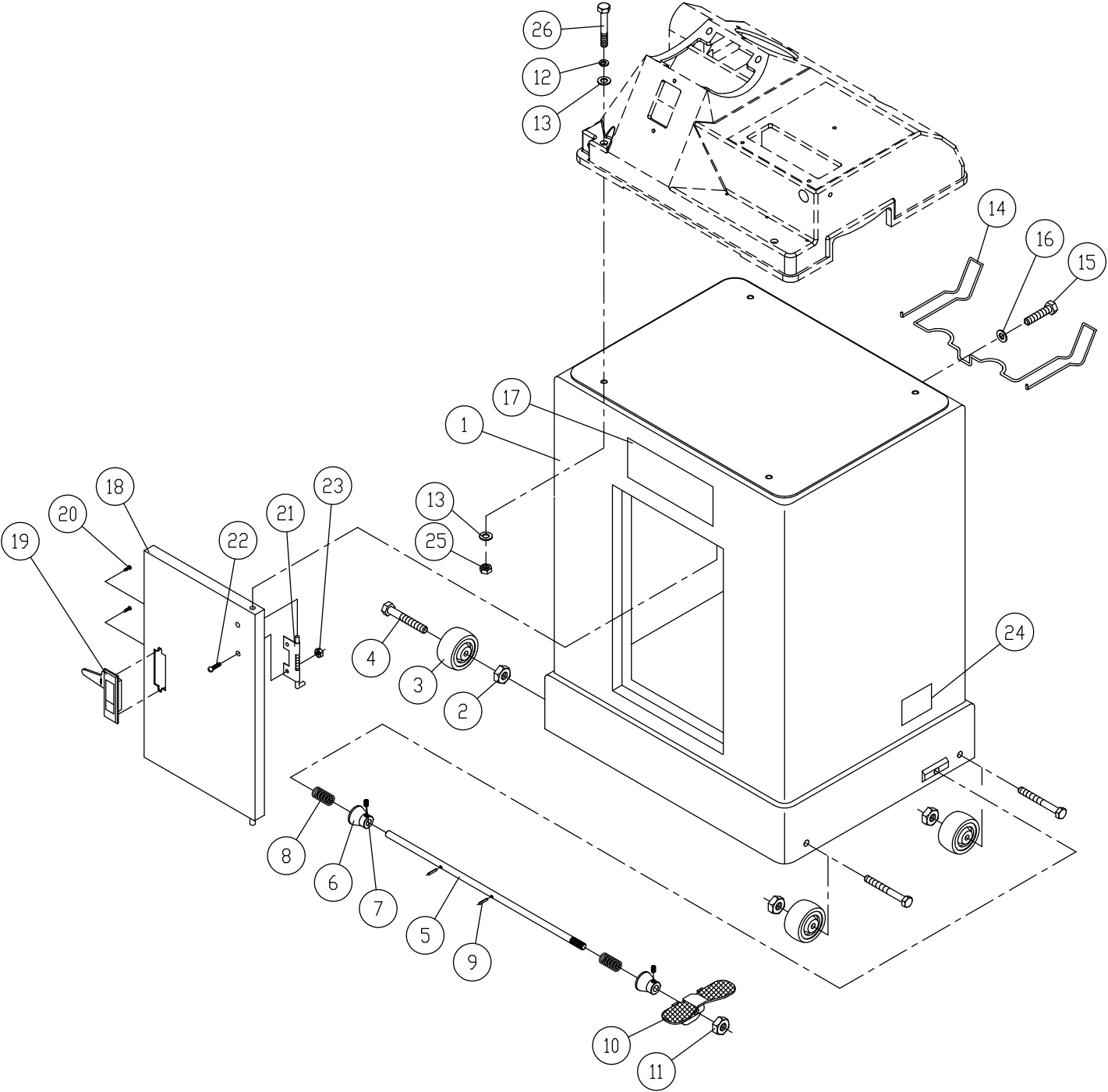



## JSG-96 Closed Stand Assembly

Index No.	Part No.	Description	Size	Qty.
1	JSG96-301	Base		1
2	JSG96-302	Lock Nut	3/8	4
3	PJE-S05	Wheel		4
4	JSG96-304	Hex Head Screw	3/8x2-1/2	4
5	JSG96-305	Shaft		1
6	PJN-S04	Eccentric Cam		2
7	JSG96-307	Set Screw	M6x10	2
8	JSG96-308	Spring		2
9	JSG96-309	Roll Pin	4x16	2
10	PJN-S02	Foot Brake		1
11	JSG96-311	Lock Nut	M10x1.5	1
12	TS-0720091	Lock Washer	3/8	4
13	TS-0680041	Flat Washer	3/8	4
14	JSG96-314	Tool Shelf		1
15	TS-0060031	Hex Head Screw	3/8x3/4	1
16	JSG96-316	Washer	3/8x1-1/8	1
17	JSG96-317	JET Plaque		1
18	JSG96-318	Door		1
19	JSG96-319	Latch		1
20	JSG96-320	Screw	M3x4	2
21	JSG96-321	Door Pivot		1
22	JSG96-127	Screw	1/4x3/8	2
23	TS-0561011	Hex Nut	1/4	2
24	JSG96-324	Braking Label		1
25	TS-0561031	Hex Nut	3/8	4
26	TS-0060131	Hex Head Screw	3/8x3	4

# JSG-96.....708595M.....1~230V, 50Hz

	colour of strands	Litzenfarben	couleur des cordons
BK	black	schwarz	noir
WH	white	weiß	blanc
BU	blue	blau	bleu
YE	yellow	gelb	jaune
RD	red	rot	rouge
BN	brown	braun	brun
GY	grey	grau	gris
GNYE	green-yellow	grün-gelb	vert-jaune
OG	orange	orange	orange
VT	violet	violett	violet

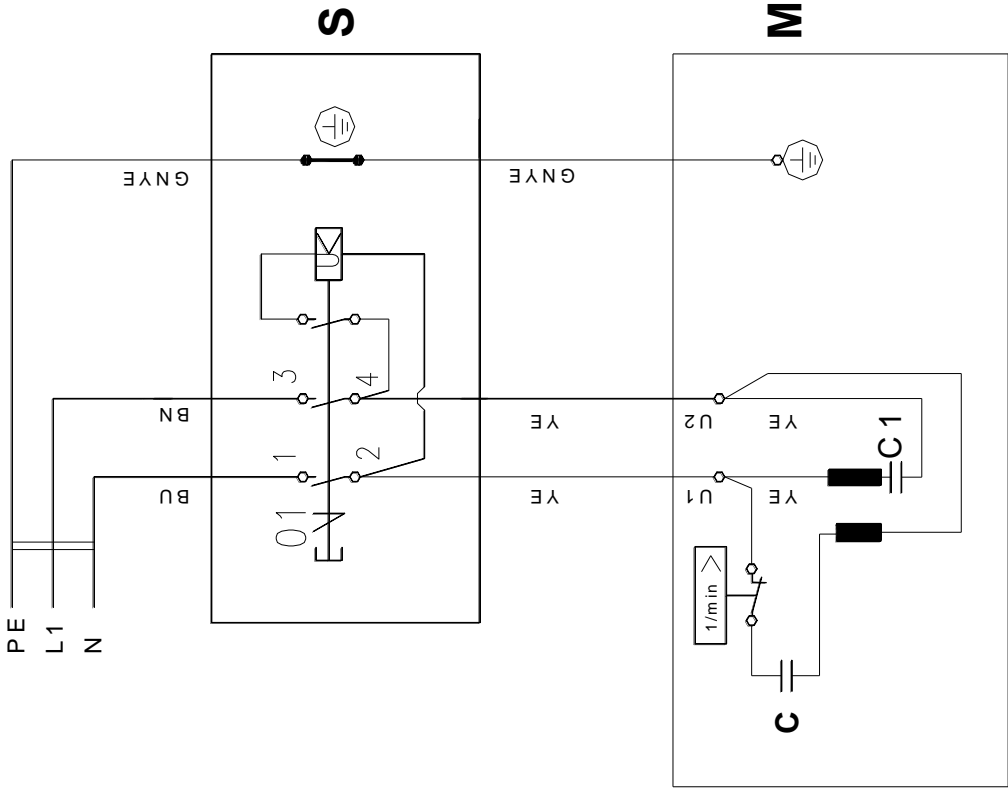

	meaning of symbol	Bedeutung der Zeichen	interprétation
M	motor	Motor	moteur
S	switch	Schalter	interrupteur
C	condenser	Kondensator	condensateur
E	electronic unit	Elektronik Einheit	unité électronique
F	fuse	Sicherung	fusible
RS	reversing switch	Drehrichtungsschalter	commu. droite/gauche
CS	centrifugal switch	Fliehkraftschalter	déclencheur centrifuge
OL	overload cut-off	Überlastschuttschalter	déclencheur surcharge
LS	limit switch	Positionsschalter	micro



